

6-4. SCHEMATIC DIAGRAM – MAIN Section (1/2) – • See page 32 for Waveforms. • See page 31 for IC Block Diagrams.

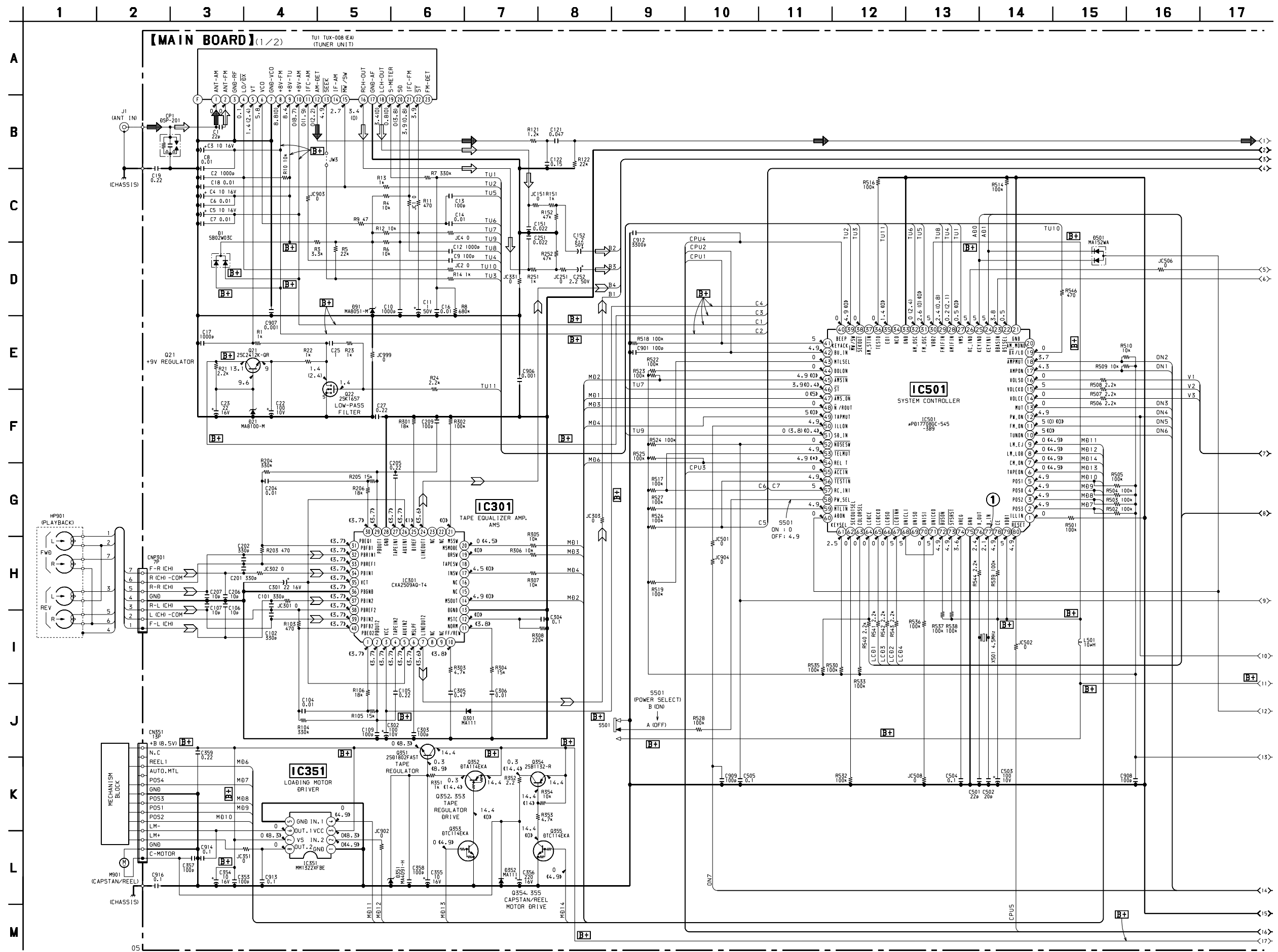

6-5. SCHEMATIC DIAGRAM – MAIN Section (2/2) – • See page 31 for IC Block Diagrams.

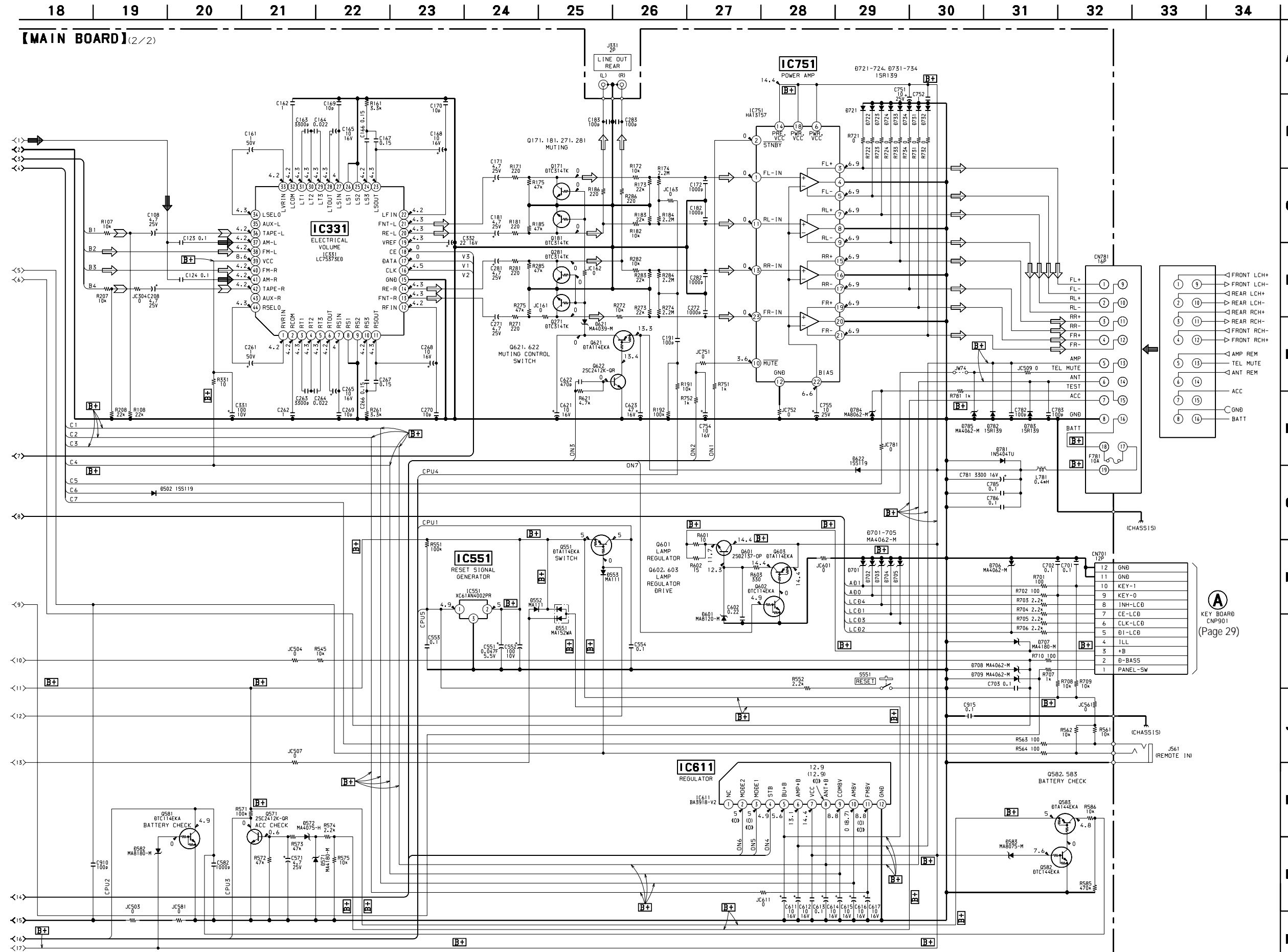

6-7. SCHEMATIC DIAGRAM – PANEL Section –

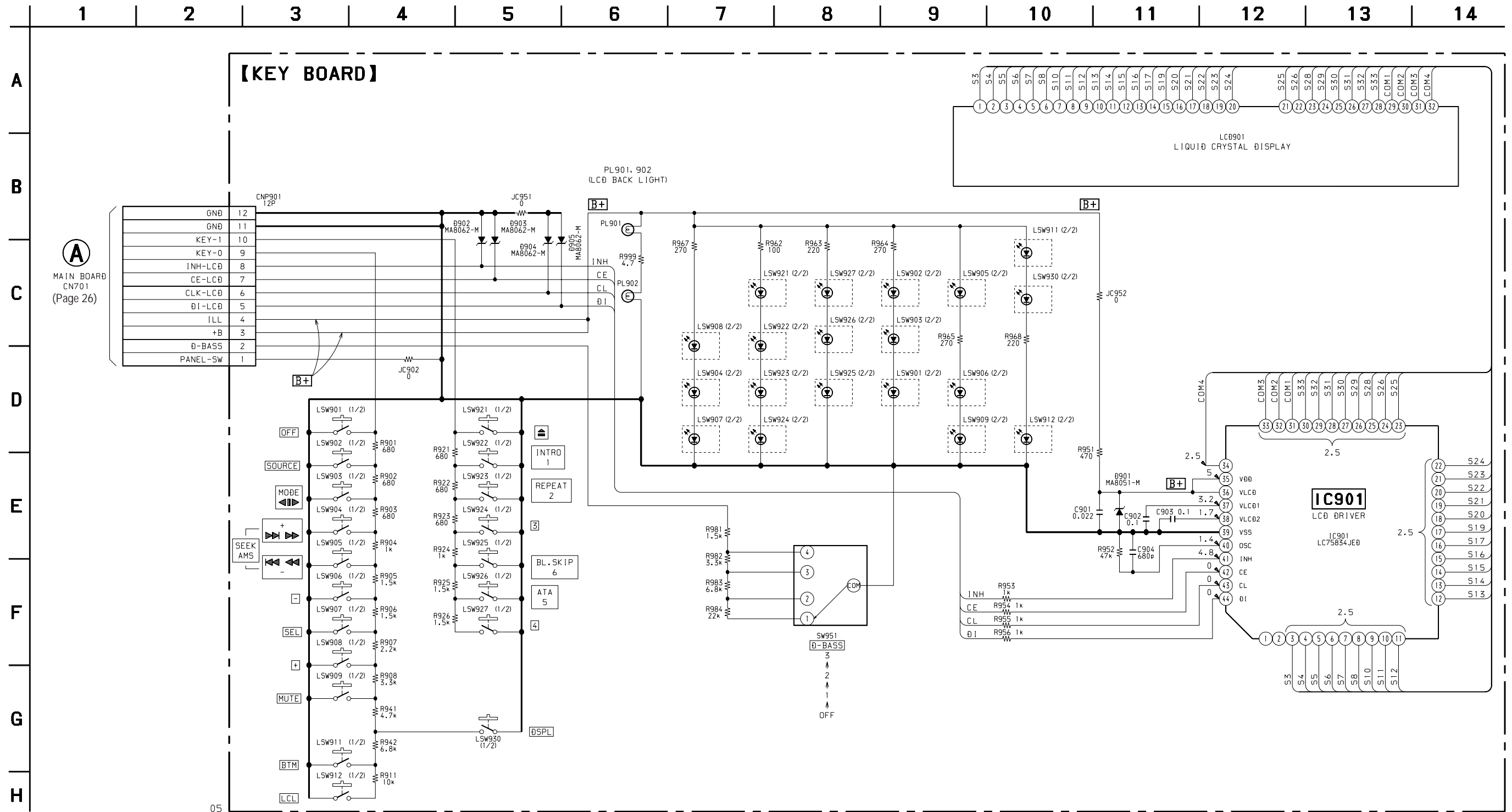

• IC Block Diagrams
– MAIN Section –

IC301 CXA2509AQ-T4

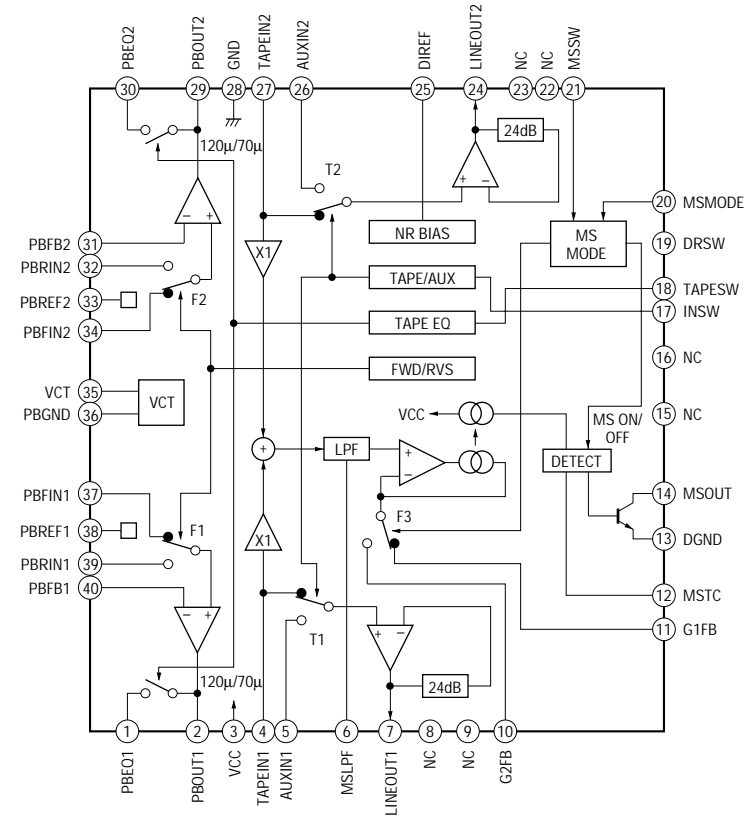

IC331 LC75373ED

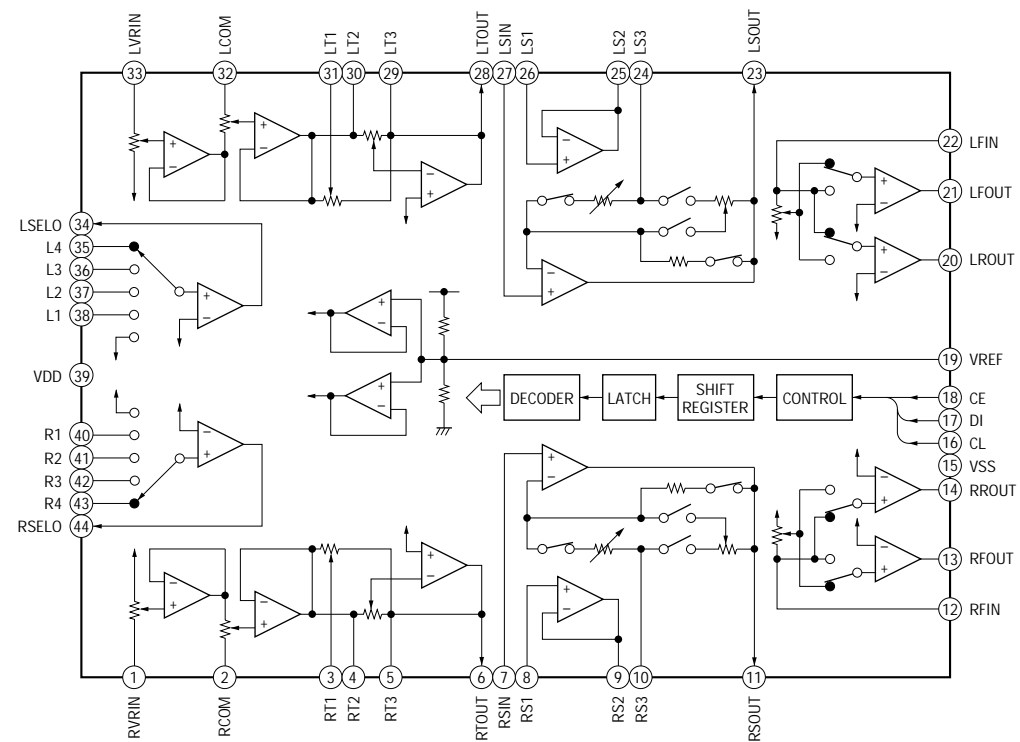

IC351 MM1322XFBE

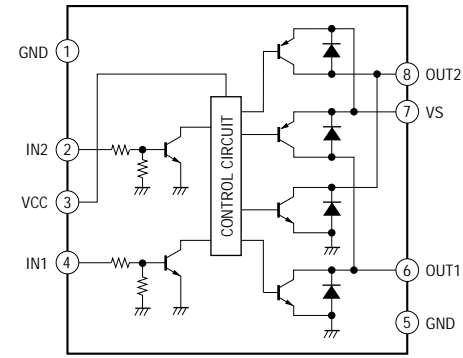

IC611 BA3918-V2

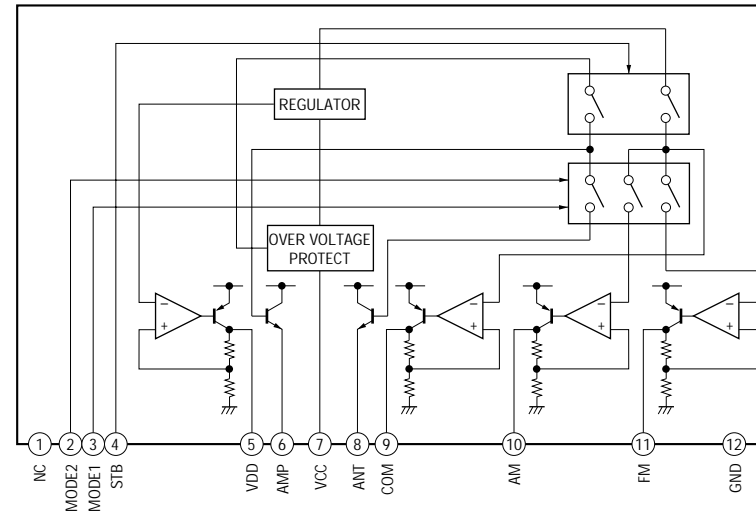

• Waveform
– MAIN Section –

① IC501 (X-IN)

